

# PT 105

## Dimensional metrology, shaft



The illustration shows the device and the GUNT Media Center on a tablet (not included).

### Description

- 10 shafts as test objects and various test equipment
- testing of: threads, diameters, lengths, depths
- digital multimedia teaching material online in the GUNT Media Center: E-Learning course, drawings, worksheets
- part of the GUNT-DigiSkills 2 learning project

As the main element of quality inspection, dimensional metrology is an essential part of practical training for all metal-working professions. The GUNT-DigiSkills 2 learning project offers different practice kits to teach basic to advanced skills in dimensional metrology.

The PT 105 practice kit is designed to teach the fundamentals of dimensional metrology in training. It focuses on testing external diameters and threads. The practice kit includes ten shafts as test objects, each of which differs in dimensions and each of which is individually marked. Selected dimensions of the shafts are tested by reference to the main drawing. Seven of the ten test objects show deviations, so that they are identified as rejects during the test.

Four different pieces of test equipment are included for taking measurements and gauging: a calliper, a depth calliper, an external micrometer and a thread gauge. Three slip gauges are also available for calibrating the measuring instruments.

The practice kit includes comprehensive didactic multimedia teaching material, which is available free of charge online in the GUNT Media Center. The E-Learning course presents fundamental knowledge and the test process in detail with appealing animations. The manual is also included as a digital version in the E-Learning course. Drawings are available as target specifications for editing the prepared digital worksheets. In this way, digital skills can be developed alongside traditional, specialist learning objectives.

All parts are clearly laid out and well protected in a stackable storage system with foam inlays.

### Learning objectives/experiments

- fundamentals of metrology: testing/measuring/gauging
- familiarisation with basic test equipment
  - ▶ calliper
  - ▶ depth calliper
  - ▶ external micrometer
  - ▶ thread gauge
  - ▶ slip gauge
- measure specified lengths, depths and diameters
- dimension test with slip gauge
- compare specified thread with gauge
- keep measuring log
- estimate/assess measurement deviations
- familiarisation with general tolerances according to ISO 2768-1
- recognise typical errors
  - ▶ systematic errors
  - ▶ random errors
- develop digital skills
  - ▶ research information in digital networks and obtain information from digital networks
  - ▶ use digital learning media, familiarisation with and use of web-based training (WBT)
  - ▶ use assistance, simulation, diagnosis or visualisation systems, e.g. QR codes, CAD viewer tool

# PT 105

## Dimensional metrology, shaft



1 slip gauge, 2 thread gauge, 3 external micrometer, 4 test objects (shaft), 5 depth calliper, 6 calliper

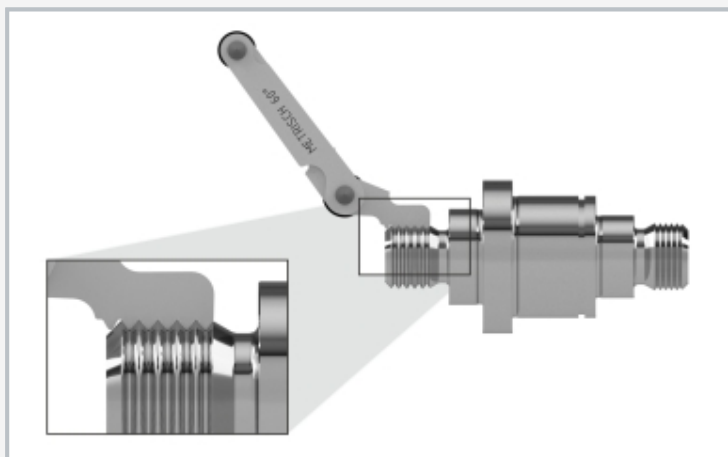

Testing a thread with the thread gauge

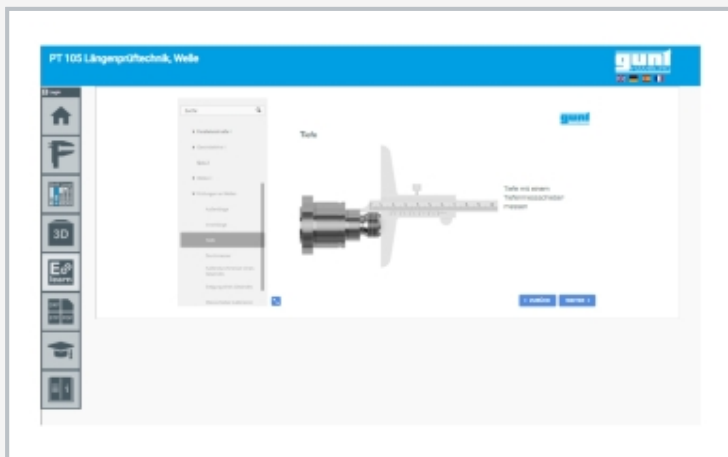

Screenshot of GUNT E-Learning course in the GUNT Media Center

### Specification

- [1] practice kit with test objects and test equipment provides basic measurement exercises of dimensional metrology for metalworking professions
- [2] part of GUNT-DigiSkills: vertical teaching of digital skills in complex learning projects
- [3] testing of threads, diameters, lengths, depths
- [4] measurement exercises on 10 test objects: shafts each with individual dimensions
- [5] stainless steel test objects
- [6] sturdy storage system with labelled foam inlay
- [7] digital multimedia teaching material online in the GUNT Media Center: E-Learning course, drawings, worksheets – with solutions for teaching personnel
- [8] online access to the GUNT Media Center

### Technical data

#### Test objects

- 10 shafts with individual dimensions
- testing of:
  - ▶ lengths
  - ▶ depths
  - ▶ diameters
  - ▶ threads
- material: stainless steel

#### Test instruments

- calliper: 0...150mm
  - ▶ reading accuracy: 0,05mm
- depth calliper: 0...150mm
  - ▶ reading accuracy: 0,05mm
- external micrometer: 25...50mm
  - ▶ reading accuracy: 0,01mm
- 3 slip gauges
  - ▶ nominal dimension: 10mm, 50mm, 90mm
  - ▶ tolerance class 2 acc. to DIN EN ISO 3650
- thread gauge
  - ▶ metric thread, Whitworth thread, Whitworth pipe thread
  - ▶ 58 leaves

LxWxH: 600x400x185mm (storage system)

Weight: approx. 8,5kg

### Required for operation

Web browser and Internet connection

### Scope of delivery

- 10 test objects
- 1 set of test equipment
- 1 online access to the GUNT Media Center with didactic accompanying material